

PC713V/PC714V

High Isolation Voltage Type, General Purpose Photocoupler

* Lead forming type (I type) and taping reel type (P type) are also available (PC713VI/PC714VI/PC713VP/PC714VP) (Page 656)
 ** TÜV (VDE0884) approved type is also available as an option.

Features

1. TTL compatible output
2. Current transfer ratio
(CTR : MIN. 50% at $I_F = 5\text{mA}$, $V_{CE} = 5\text{V}$)
3. Low collector dark current
(I_{CEO} : MAX. 10^{-7}A at $V_{CE} = 20\text{V}$)
4. High isolation voltage between input and output (V_{iso} : 5 000V_{rms})
5. Recognized by UL, file No. E64380

Applications

1. System appliances, measuring instruments
2. Registers, copiers, automatic vending machines
3. Electric home appliances such as fan heaters
4. Medical instruments, physical and chemical equipment
5. Signal transmission between circuits of different potentials and impedances

Absolute Maximum Ratings (Ta = 25°C)

Parameter	Symbol	Rating	Unit
Forward current	I_F	50	mA
*1 Peak forward current	I_{FM}	1	A
Input			
Reverse voltage	V_R	6	V
Power dissipation	P	70	mW
Collector-emitter voltage	V_{CEO}	35	V
Emitter-collector voltage	V_{ECO}	6	V
*2 Collector-base voltage	V_{CBO}	35	V
*2 Emitter-base voltage	V_{EBO}	6	V
Output			
Collector current	I_C	50	mA
Collector power dissipation	P_C	150	mW
Total power dissipation	P_{tot}	170	mW
*3 Isolation voltage	V_{iso}	5 000	V _{rms}
Operating temperature	T_{opr}	-25 to +100	°C
Storage temperature	T_{stg}	-40 to +125	°C
*4 Soldering temperature	T_{sol}	260	°C

*1 Pulse width $\leq 100 \mu\text{s}$, Duty ratio = 0.001
 *2 Applies only to PC713V
 *3 40 to 60%RH, AC for 1 minute
 *4 For 10 seconds

Outline Dimensions (Unit : mm)

PC713V

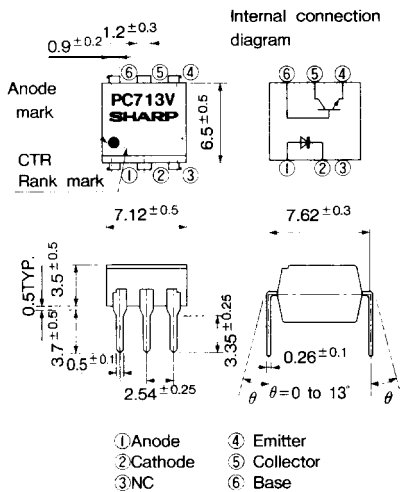

PC714V

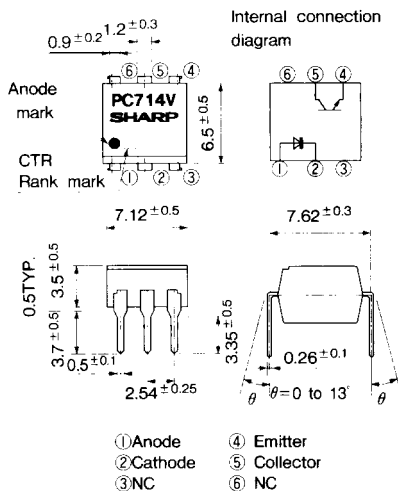

6

Photocouplers

■ Electro-optical Characteristics

(Ta = 25°C)

Parameter		Symbol	Conditions	MIN.	TYP.	MAX.	Unit	
Input	Forward voltage	V_F	$I_F = 20\text{mA}$	—	1.2	1.4	V	
	Peak forward voltage	V_{FM}	$I_{FM} = 0.5\text{A}$	—	—	3.0	v	
	Reverse current	I_R	$V_R = 4\text{V}$	—	—	10	μA	
	Terminal capacitance	C_t	$V = 0, f = 1\text{kHz}$	—	30	250	pF	
output	Collector dark current	I_{CEO}	$V_{CE} = 20\text{V}, I_F = 0, {}^*5R_{BE} = \infty$	—	—	10^{-7}	A	
Transfer characteristics	Current transfer ratio	CTR	$I_F = 5\text{mA}, V_{CE} = 5\text{V}, {}^*5R_{BE} = \infty$	50	—	600	%	
	Collector-emitter saturation voltage	$V_{CE(sat)}$	$I_F = 20\text{mA}, I_C = 1\text{mA}, {}^*5R_{BE} = \infty$	—	0.1	0.2	V	
	Isolation resistance	R_{ISO}	DC500V, 40 to 60%RH	5×10^{10}	10^{11}	—	Ω	
	Floating capacitance	C_f	$V = 0, f = 1\text{MHz}$	—	0.6	1.0	pF	
	Cut-off frequency	Response time	Rise time	$V_{CE} = 2\text{V}, I_C = 2\text{mA}$	—	4	18	μs
			Fall time	$R_L = 100\Omega, {}^*5R_{BE} = \infty$	—	3	18	μs

*5 Applies only to **PC713V**

*6 Classification table of current transfer ratio is shown below

Model No.	Rank mark	CTR(%)
PC713V1/PC714V1	A	80 to 160
PC713V2/PC714V2	B	130 to 260
PC713V3/PC714V3	c	200 to 400**
PC713V5/PC714V5	A or B	80 to 260
PC713V6/PC714V6	B or C	130 to 400
PC713V8/PC714V8	A, B or C	80 to 400
PC713V/Pc714v	A, B, C or no marking	50 to 600

Measurement conditions

$I_F = 5\text{mA}$

$V_{CE} = 5\text{V}$

$T_a = 25^\circ\text{C}$

Fig. 1 Forward Current vs. Ambient Temperature

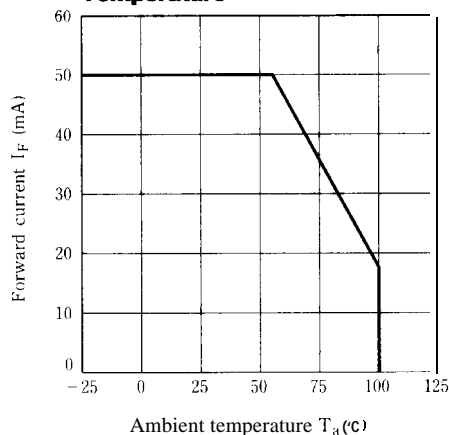

Fig. 2 Collector Power Dissipation vs. Ambient Temperature

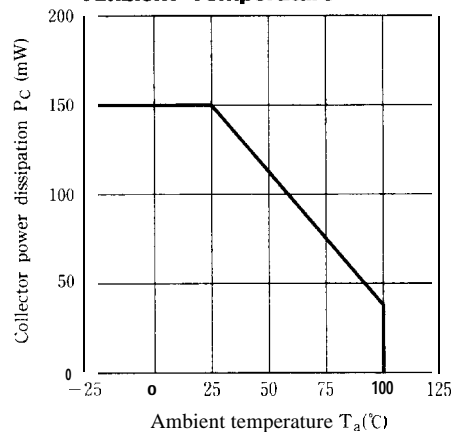

Fig. 3 Peak Forward Current vs. Duty Ratio

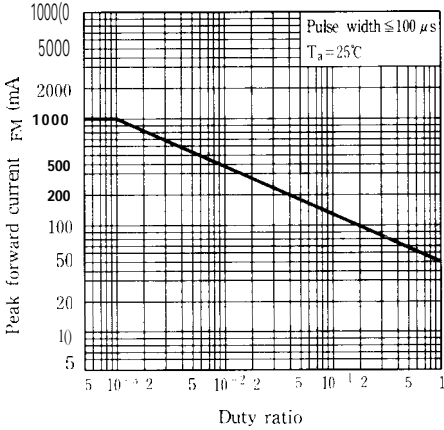

Fig. 4 Forward Current vs. Forward Voltage

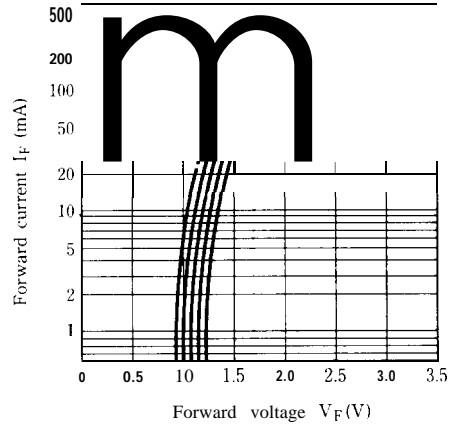

Fig. 5 current Transfer Ratio vs. Forward Current

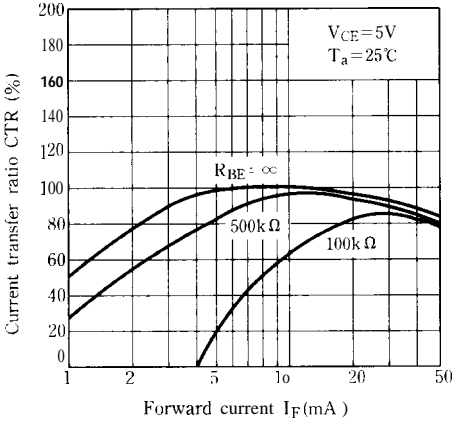

Fig. 6 Collector Current vs. Collector-emitter Voltage

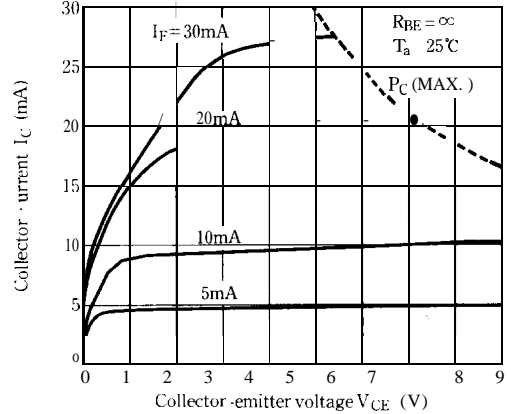

Fig. 7 Relative Current Transfer Ratio vs. Ambient Temperature

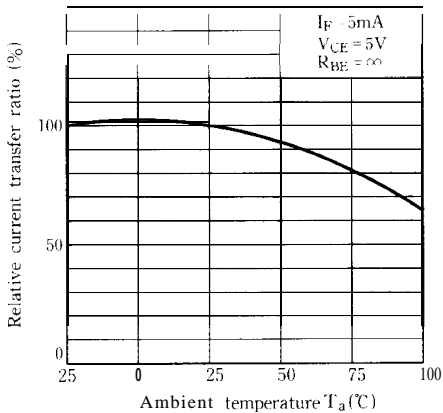
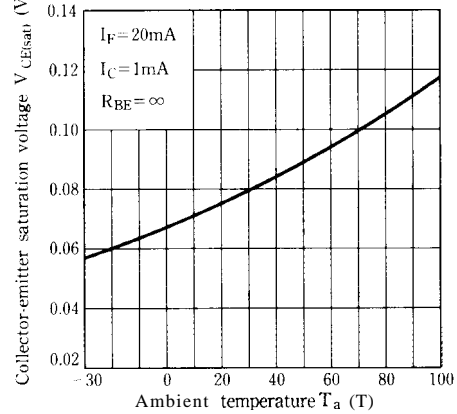

Fig. 8 Collector-emitter Saturation Voltage vs. Ambient Temperature



6
rs
Ph

Fig. 9 Collector Dark Current vs. Ambient Temperature

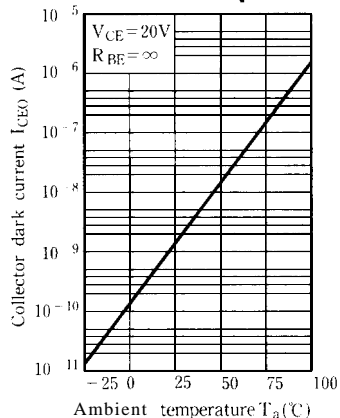

Fig.10 Collector -base Dark Current vs. Ambient Temperature

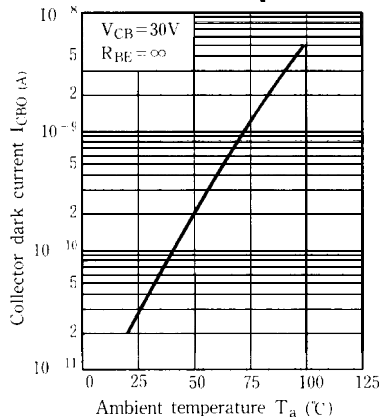

Fig.11 Response Time vs. Load Resistance

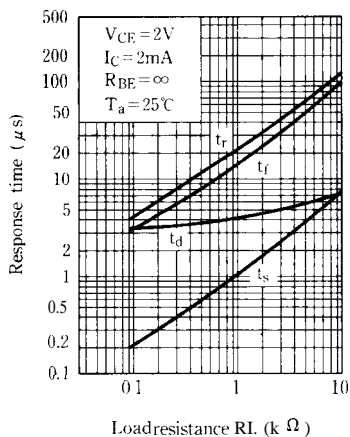
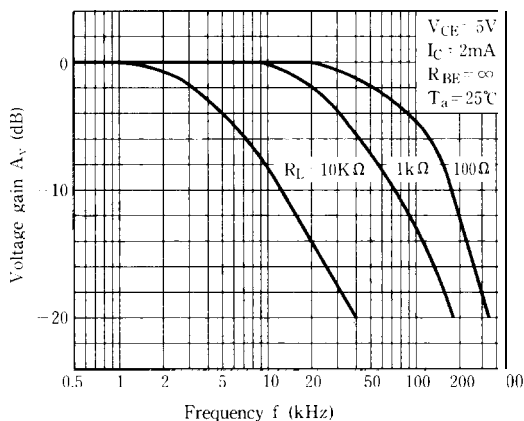
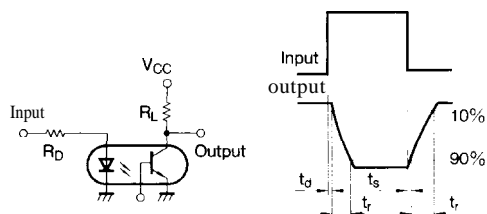

Fig.12 Frequency Response



Test Circuit for Response Time



(PC714V has no base terminal.)

Test Circuit for Frequency Response

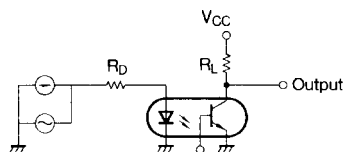

(PC714V has no base terminal.)

● Please refer to the chapter "Precautions for Use" (Page 78 to 93)